

Installation & Operating Manual

Inthermo Mobile

Radiant Heater

Warnings

(Insert company name here) equipment must be installed and maintained in accordance with the requirements of the Codes of Practice or rules in force.

Utemporumi alitas volo beatiae as debisquid ut ea nimir nonseque la sit inullentur aperum endaeestis et apicati ipsam, odi deluptatis dolorest perum int endio occupatae con resseceaque maio. Ut voluptati omnim aut



Operation, maintenance and servicing manual

Index

- 1 Health & safety details
- 2 Technical details
- 3 Operating instructions
- 4 Cleaning & maintenance
- 5 Servicing instructions
- 6 Fault finding
- 7 Spare parts



1 Health & safety details

Important

Read these instructions before use.

This appliance must be installed in accordance with such regulations as are in force.

This appliance is for indoor use only.

Subject to compliance to clearance distances and flue requirements detailed in these instructions the heater can be used inside marquees.

Only use in a well ventilated area. See technical details Section 2.

Prior to use always ensure the wheels are locked see section 3 step 1.

The heater is not for domestic use.

The heater is designed for space heating only.

Do not use the heater in basements or below ground level.

This appliance is fitted with a hose and regulator.

These instructions must be given to the user.

Suitable gloves should be worn when handling this equipment.

Observe the cool down period see section 3 step 7 and never handle the heater when hot.

Never place any objects, particularly combustible materials on top of the heater and always ensure that flues are not obstructed.

Gas leaks

Propane gas is highly flammable and heavier than air. Consequently in the event of a gas leak there is a risk of explosion.

Prior to use check gas supply connections with water/washing up liquid solution. Never use a naked flame for checking for gas leak. In the event that bubbles are noted either rectify if considered competent or consult your supplier.

Do not use the heater until the fault is rectified.

In the event of a gas leak evacuate people from the immediate area and open doors and windows.

Do not operate electrical switches or isolate the electrical connector from the heater.

If a lot of gas has escaped call the Fire Service.

After ventilating the room turn off the gas valve, and disconnect the electrical connector to the heater.

If the appliance is hot leave to cool then with the aid of a competent person identify and rectify the source of the leak.

Gas cylinders

This heater is designed to be used with 47kg propane bottles.

Gas cylinders are heavy, never attempt to lift a cylinder, full or empty, by yourself. Always get help.

Keep cylinders upright at all times during use, transporting and when stored.

Liquid gas can cause severe freeze burns so avoid skin contact by wearing gloves when making connections or handling the cylinder. If ice is noted on the cylinder ensure that cylinder is not leaking. If leaking is suspected do not use the cylinder.

Do not drop or knock a gas cylinder in that damaged cylinders can be dangerous.

Do not store full or empty bottles in the operating area of the heater and never apply heat to the cylinder.

Always ensure that the cylinder is located in the arc of the bracket on the rear of the unit. Then pass the safety chain around the cylinder and through the keyhole slot. See section 3 step 2.

After location/attachment of the cylinder take the hose from the housing on the rear of the unit and using the spanner provided attach the hose to the cylinder as indicated. See section 3 step 3.

Electrical supply

The heater is suitable for use with either a 230V/50Hz or 110V/50Hz supply. A selector switch enables the user to choose the desired voltage. See section 3 step 4.

Only female electrical connectors compatible to the male connectors on the rear of the unit must be used.

Always switch off and unplug the equipment when not in use.

Note There are cut-outs incorporated on both 110 and 230 Volt supplies. Resetting of the switches is detailed in section 3.

2 Technical details

Model		MH26AS	MH26BS
Heat input	kW	26	26
gas			
Gas type		Propane G31	
Gas category		l3p(37)	l3p(50)
Supply press	mbar	37	50
Injector size		2.6	2.4

MOBILE RADIANT HEATER

Electrical supply		230V/50Hz/3A fuse or 110V/50Hz/6A fuse
Electrical input		170W
Weight		180kg
Hose		1.5m lg, 80mm ID approved to EN 1763-1 BS3212 (UK Only)
Regulator		4kg/h4kg/h 37mbar50mbar
Min Room size		260m ³
Required ventilation		650cm ²

Countries of destination GB,

IE, BE, CH, FR, DE, ES & PT.

3 Operating instructions

Ensure that you have read all other detail included in these instructions prior to following the operating instructions detailed.

Move heater to desired operating position and observe the clearance distances detailed in Figure 1.

Figure 1 Clearance distance diagram

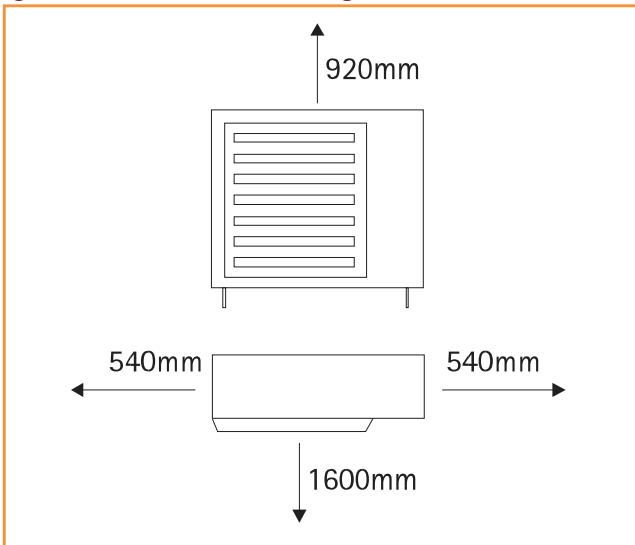

Step 1



Depress the locking mechanism on both wheels to prevent the heater moving during operation.

2

Step 2



Locate the gas cylinder in the arc of the bracket on the rear of the unit. Pass the chain around the cylinder and through the keyhole slot to ensure that the cylinder is attached to the heater during operation.

Step 3



Uncoil the hose from the recess on the rear of the unit and connect to the gas cylinder. Ensuring that the hose is not twisted. (Note left hand thread).

Step 4



The heater can be operated on either a 110V or 230V electrical supply by attachment to the connectors on the rear of the unit. After insertion of the connector ensure that the voltage selector switch (located above the connectors) is set to the desired setting.

Step 5



Set the thermostat to your desired air room temperature.

Step 6



Switch the rocker switch on the front of the unit to the ON position.

After switching on the heater, ignition is controlled by the automatic ignition unit incorporated on the burner assembly. Firstly, the combustion and convection fans will be heard running a delay of 15-20 seconds and the igniter will be heard to spark. If ignition does not occur then there is probably air in the gas line. Re-ignition can be attempted by switching the rocker switch on the front of the unit from ON to OFF then ON again.

If after several ignition attempts the heater does not light, consult your supplier for advice. **Step 7 Disconnection**

When heating is complete, turn OFF the gas supply. Leave the electric supply turned ON to enable the combustion fan to operate for 10 minutes to cool the tubes prior to moving.

After cooling is complete, turn OFF the electric supply and remove the electrical connector.

Turn OFF and disconnect the gas supply. Recoil the hose in the recess provided.

Remove the chain securing the gas cylinder to the heater and move the cylinder.

Unlock the wheels to enable the heater to be moved to a storage location or returned to your supplier.

Note Connecting and disconnecting cylinders MUST take place in a flame free atmosphere. When the appliance is not going to be used for a period of time the unit MUST be disconnected from the electrical mains and gas cylinder.

4 Cleaning & maintenance

The hose should be checked regularly for its integrity, if any damage is found the hose must be replaced. See Technical details for hose details.

Ensure that the air intakes on the top and bottom of the heater are clean and free from any blockages.

5 Servicing instructions

Health and safety

This heater should be serviced annually.

These instructions are intended to be used only by competent service engineers, and details all the service operations that are authorised by the manufacturer.

Isolate gas and electrical supplies before carrying out any repair work. Always test for gas soundness with a suitable leak detection fluid. Use gloves and safety glasses.

Required tools

4mm Allen keys.

Phillips screwdriver.

6" Adjustable spanner.

Combustion fan



Remove Combustion fan by unplugging the electrical connection from the burner/control assembly and remove the fan securing pinch screw.

Disconnect the flue spigot from the top of the unit. The fan will now slip off the radiant tube. Inspect the main fan impeller and remove any dust by brushing with a soft brush. Similarly remove any dust from the finger guard covering the secondary (cooling) impeller and the mesh aperture in the motor cover.

Ensure that the impeller turns freely and that there is not excessive play in the bearings.

Do not replace fan until radiant tube inspection has been completed.

4



Radiant tube inspection



Brush away any dust on the exterior of the radiant tubes.

Inspect the radiant tubes internally.

If there is any appreciable build up of dust or deposits the tubes should be cleaned internally. The two tubes can then be cleaned by passing rods and a suitable scraper through them or by use of an industrial vacuum cleaner with a long extension tube.

Reflector

Although not considered part of an annual routine service, the condition of the reflector should be noted.

The reflector can be cleaned with a soft cloth and detergent in water. A mild non abrasive metal polish may be used in cases of extreme discolouration. Dirty reflectors will decrease the heat radiation upwards by 3-4%.

Removal of burner/control assembly



Remove the burner/control assembly by disconnecting the gas and electrical supply, fresh air inlet (if fitted) and the fan electrical connection.

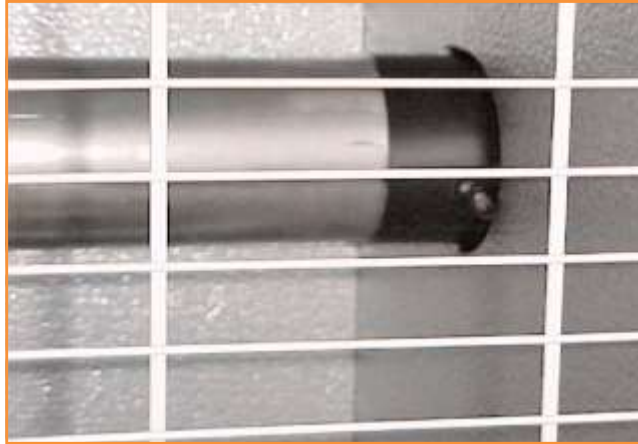

Remove the burner fixing pinch screw and draw the assembly off the radiant tube.

Note If an extended allen key is not available remove the front grille for access to the pinch screw.

Burner/electrode assembly

Inspect the burner electrode assembly by removing six dome head screws securing the combustion chamber's cover plate on top of the burner box, taking care not to damage the sealing gasket.

Remove the burner head by unscrewing it from the injector, taking care not to drop it onto the leads of the ignition electrodes.

Renew the electrode assembly if it is not in good condition.

The assembly is then lifted out of the combustion chamber and the two connection cables disconnected.

If the electrode assembly is in good order check the spark electrode gap. This should be $3.5\text{mm} \pm 0.5\text{mm}$. Adjust the gap if necessary by bending the earth rod.

Refit the electrode assembly in the reverse order of removal, ensuring that the electrical connections to the assembly

are the correct way round and secure.

Inspect the injector and clean as necessary. Do not broach out.

To remove the injector with the burner head removed, unscrew the injector from its carrier using a spanner on the hexagon portion of its body. When replacing the injector ensure that it is fully tightened in its carrier. Replace the burner head. Replace the combustion chamber plate cover, renewing the sealing gasket if this is not in good condition.

To replace gas safety control valve

Remove combustion chamber cover as on previous page. Remove control housing cover by removing the two dome headed fixing screws. Remove burner head and the 2 screws holding inlet gas connection supply support plate. Disconnect the gas valve electrical connection, marking each connection. The gas valve and injector can now be removed as an assembly. Using an approved pipe joining compound on pipe threads, refit the pipe fittings onto the replacement control valve. Replace the control valve into the control housing (refit burner onto injector holder before tightening inlet support plate screws). Carry out commissioning, setting the burner pressure to that indicated on the data badge.

To replace the electronic sequence controller

Remove the safety control housing cover by unscrewing three screws.

Disconnect the electrical connector on the side of the electronic sequence controller. Unplug the single grey high tension lead from the electronic sequence controller. Remove the plastic clips and replace the sequence controller using the high tension lead (grey) from the old controller unless its insulation is damaged.

Refit the electrical connector into the sequence controller and high tension leads into its connector and fasten the controller with the plastic clips.

To replace the vacuum proving switch

Disconnect the silicon rubber tube connections at the vacuum switch.

Disconnect the three push on connectors from the vacuum switch. Remove the two screws securing the vacuum switch and slip the vacuum switch out of the control housing. Refitting is a reversal of the above, taking care to correctly reconnect the three cables.

MOBILE RADIANT HEATER

Note If it is not possible to leave the unit in a safe condition the burner plug should be removed to prevent the unit from operating.

MOBILE RADIANT HEATER

Figure 2 Model Inthermo burner assembly

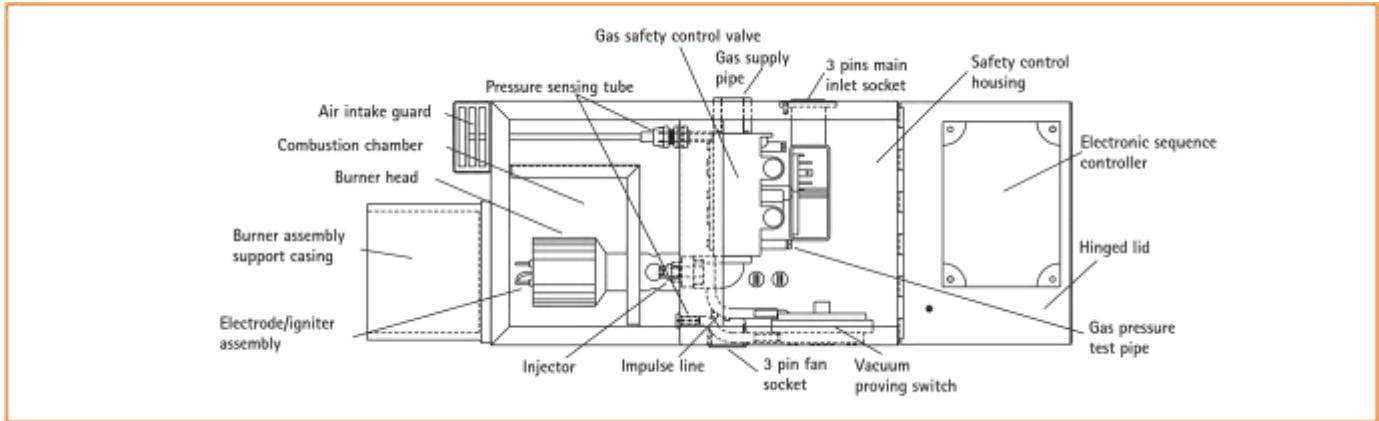

Figure 3 S.I.T. vacuum proving switch

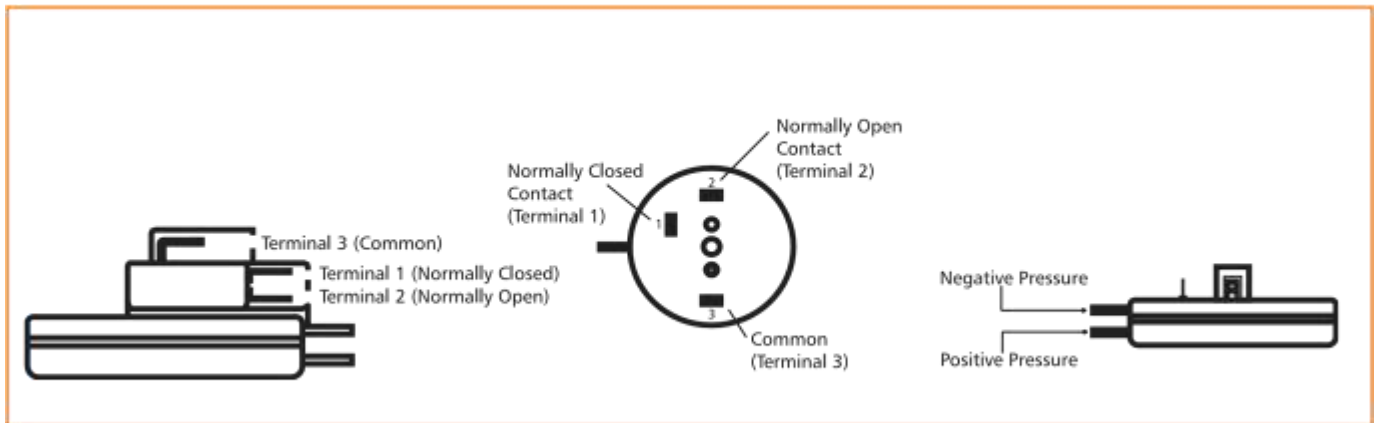
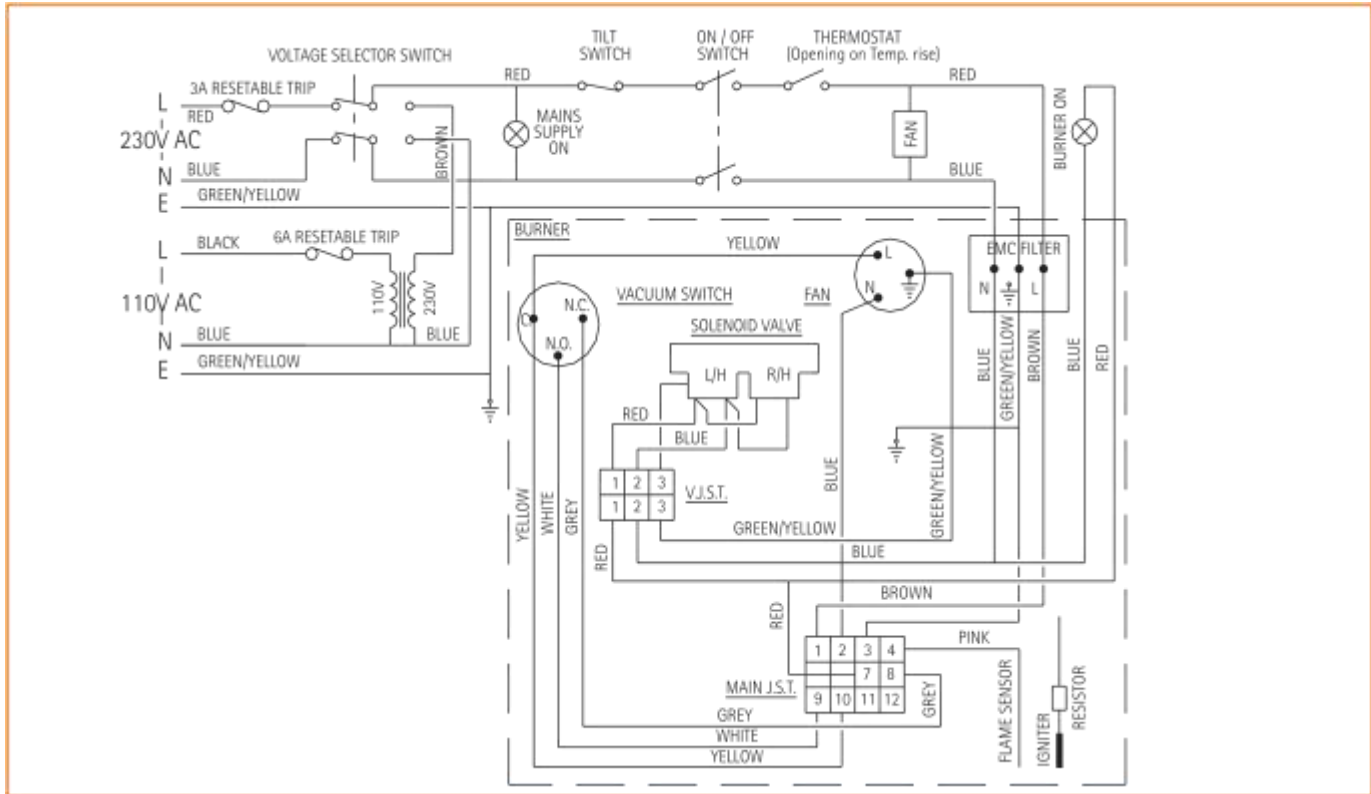

Figure 4 Wiring diagram





6

6 Fault finding

Symptoms	Possible causes	Remedy
Burner will not start	Incorrect voltage selected	
Red 'mains on' does not illuminate.	External controls, thermostats, time switch etc. not calling for heat.	Adjust controls.
	Fuse blown.	Check for short circuit in wiring or individual electrical components.
Red light illuminates.	Fans connector plug not fully engaged.	Engage securely.
	Loose electrical connection.	Check all connections.
	Fan seized or faulty motor.	Replace fan, recommission heater, checking gas pressure settings.
	Sequence controller relay failing to pull in and/or hold in.	Check vacuum switch is satisfactory, replace sequence controller.
	Vacuum switch not returning to normal (switch off) position.	Replace vacuum switch.
Fan starts but burner does not attempt ignition.	Insufficient vacuum generated by fan.	Clean fan blades with soft bristle.
	Blocked emitter tube.	Clean emitter tube internally.
	Combustion chamber cover permitting air leakage.	Examine condition of sealing gasket, tighten down lid securely.
	Vacuum impulse line between combustion chamber and vacuum switch insecure or defective.	Fix securely in place.
	Vacuum switch 'pulls in' but electronic sequence controller does not proceed to programme	Replace burner sequence controller unit but first check that the cause of failure is not a short on

	ignition sequence.	output circuit, by measuring resistance between pins 2 and 7 of burner control unit plug. A reading of 10,000 ohms indicates short circuit on gas valve burner indicator light or associated wiring.
Burner proceeds to ignition stage (normally indicated by audible spark valve energised and 'burner on' light illuminated) but burner does not light.	No spark.	Check electrode for cracks – replace if necessary. Check high tension connections are secure. Check spark gap is $3.5 \pm 0.5\text{mm}$. If no high tension output from electronic controller, replace controller.
	Gas safety valve faulty or defective.	Replace solenoid operator section of gas valve.
	Insufficient gas pressure.	Set burner pressure to that indicated on data badge (see commissioning).
Burner lights but shuts down after a few seconds.	Inadequate flame signal. This can be verified by connecting a sensitive micrometer in series with the violet wire which passes through the combustion chamber bulkhead. The correct reading should be $5\mu\text{A} \pm 1\mu\text{A}$.	Replace electrode. Check connections to electrodes and terminal 4 of electric sequence controller plug Replace the electronic sequence controller.
	Flame unstable.	Check cleanliness of burner and set burner pressure as indicated on data badge.
	Inadequate gas supply. Observe burner gas pressure with all heaters operating.	If gas pressure drops below that indicated on the data badge, examine gas supply pipework for excessive pressure loss.
	Insufficient vacuum at combustion chamber causing vacuum switch to cut off.	Clean fan blades with soft bristle brush. Inspect tube internally and clean if necessary (see servicing instructions).
		If problem persists, replace vacuum switch.
Heater shuts down after operating for a period of time.	Refer to above.	
Electrical supply tripped and heater fails to operate.	Reset switch activated.	Reset, if problem persists. Consult your gas supplier

7 Spare parts

Photograph	Description	Part Number	Photograph	Description	Part Number
	Combustion fan	200190		Electrode assembly	3175
	Convection fan	200171			
	Injector	2273			
	Burner chamber gasket	3190			
	Gas valve	2052			
	Pressure switch	2190			
	Electronic controller	2015			
	U-Bend Aluminised	200169			
	U-Bend Stainless Steel	200170			
	Hose	200210			
	Clip	200211			
	Regulator	200213			

8

Notes



Andrews Sykes Hire Group PLC

St David's Court
Union Street
Wolverhampton
WV1 3JE

Tel: 0800 211 611

Web: www.andrews-sykes.com

AFFIX AGENTS DETAILS HERE